

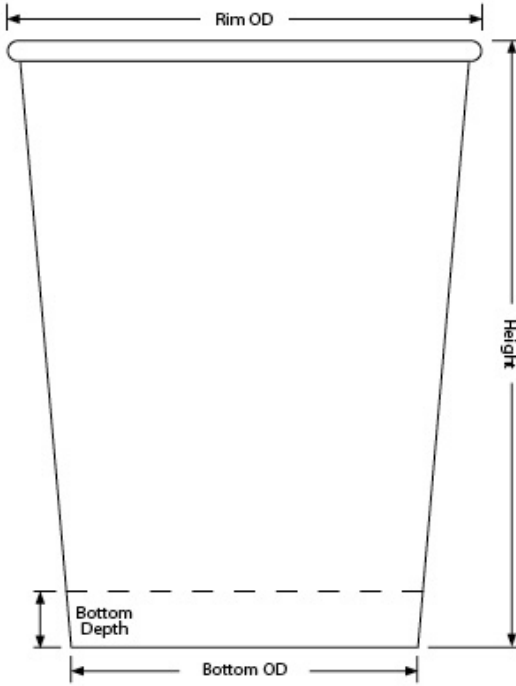

# MN17 17oz Drink Cup (17)

17oz VANISH Plastic-FREE Paper Cup



---

**Capacity:** 17.59oz / 520.00ml

---

**Material:** 16.7pt Bio Natura Plastic-FREE, Compostable, Recyclable Paper PEFC Certified

---

**Minimum:** 2,000 pieces

---

**Height:** 4.682"  $\pm$ .015

---

**Rim Height:** 0.150"  $\pm$ .010

---

**Rim OD:** 3.688"  $\pm$ .010

---

**Bottom OD:** 2.665"  $\pm$ .010

---

**Bottom Depth:** 0.414"  $\pm$ .010

---

**Shipping:** FOB NV Made in the USA

---

## MN17 Standard Case Pack Configuration

Box Dimensions: 18.88"x15.19"x25.28"

Box Volume: 4.20 Cubic Feet

Box Weight: 34 lbs

Box Content: 1,000 Pieces

Pallet Dimensions: 40.00"x48.00"x96"

Pallet Weight: 759 lbs

Pallet Content: 21,000 Pieces / 21 Boxes

SEE LID OPTIONS ON LAST PAGE



## Lid Options for MN17 (Matte)

17oz VANISH Plastic-FREE Paper Cup



### Reusable Basic Lids

- Reusable, injection molded
- Black & white standard
- With & without straw slot
- Case: 1,000 - 14 lbs



### Clear Single-Use Lid

- Clear, thermo-formed
- With & without straw slot
- Case: 1,000 - 7 lbs



### Clear High Dome Lid

- Clear, thermo-formed
- With top opening
- Case: 1,000 - 9 lbs