

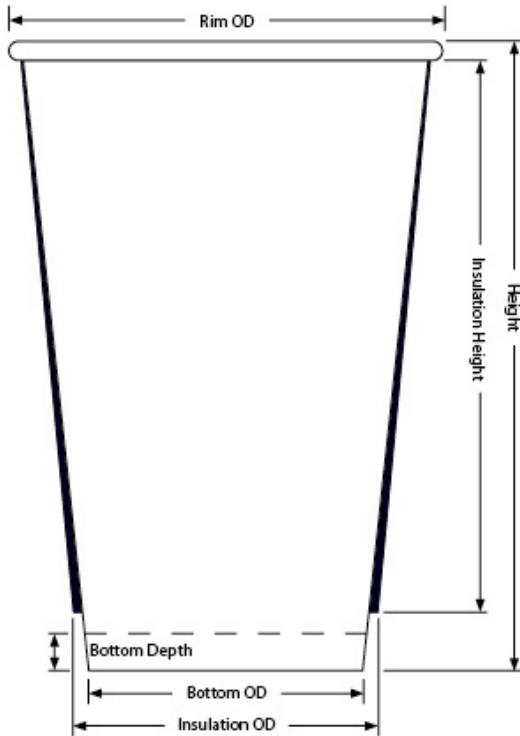

# XHD6 16oz Drink Cup (D6)

16oz Double Wall Recycled Paper Cup



---

**Capacity:** 16.00oz / 473.00ml

---

**Material:** 16.5pt Recycled Paper, Poly 1-side, 35% Sustana  
EnviroLife Post-Consumer Recycled Fiber, FSC SFI  
PEFC Certified

---

**Minimum:** 1,000 pieces

---

**Height:** 5.099"  $\pm$ .015

---

**Rim Height:** 0.150"  $\pm$ .010

---

**Rim OD:** 3.515"  $\pm$ .010

---

**Bottom OD:** 2.215"  $\pm$ .010

---

**Bottom Depth:** 0.301"  $\pm$ .010

---

**Shipping:** FOB NV Made in the USA

---

## XHD6 Standard Case Pack Configuration

Box Dimensions: 23.75"x18.25"x14.01"

Box Volume: 3.51 Cubic Feet

Box Weight: 27 lbs

Box Content: 500 Pieces

Pallet Dimensions: 40.00"x48.00"x89"

Pallet Weight: 693 lbs

Pallet Content: 12,000 Pieces / 24 Boxes

SEE LID OPTIONS ON LAST PAGE

## Lid Options for X2D6 (Gloss), XHD6 (Matte) 16oz Double Wall Recycled Paper Cup



### P2 Printed Snap-Fit Paper

- Hi-Definition, Full Color
- Customizable
- Seamlessly registered text
- Uninterrupted text
- Three week leadtime
- Case: 500 - 10 lbs



### Clear Single-Use Lid

- Clear, thermo-formed
- With & without straw slot
- Case: 1,000 - 8 lbs



### Clear High Dome Lid

- Clear, thermo-formed
- With top opening
- Case: 1,000 - 10 lbs



### Cappuccino Lid

- White/Black, thermo-formed
- Vented lid
- Case: 1,000 - 8 lbs