

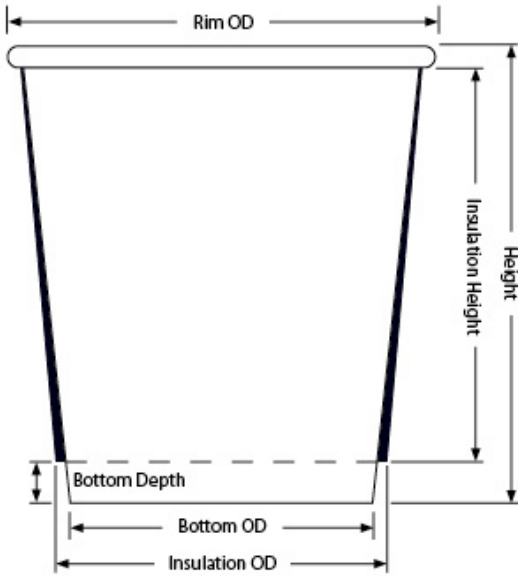

# XHD9 9oz Drink Cup (D9)

8/9oz Double Wall Recycled Paper Cup



---

**Capacity:** 8.80oz / 260.00ml

---

**Material:** 16.5pt Recycled Paper, Poly 1-side, 35% Post-Consumer Recycled Fiber, FSC SFI PEFC Certified

---

**Minimum:** 1,000 pieces

---

**Height:** 3.356"  $\pm$ .015

---

**Rim Height:** 0.150"  $\pm$ .010

---

**Rim OD:** 3.143"  $\pm$ .010

---

**Bottom OD:** 2.215"  $\pm$ .010

---

**Bottom Depth:** 0.301"  $\pm$ .010

---

**Shipping:** FOB NV - Made in the USA

---

9oz Drink Cup (D9) available in [Double Wall](#)  
[Plastic-Free Double Wall](#)

---

## XHD9 Standard Case Pack Configuration

Box Dimensions: 22.00"x13.06"x15.33"

Box Volume: 2.55 Cubic Feet

Box Weight: 19 lbs

Box Content: 500 Pieces

Pallet Dimensions: 40.00"x48.60"x97"

Pallet Weight: 729 lbs

Pallet Content: 18,000 Pieces / 36 Boxes

SEE LID OPTIONS ON LAST PAGE

# Pallet for X2D9 (Gloss), XHD9 (Matte)

8/9oz Double Wall Recycled Paper Cup

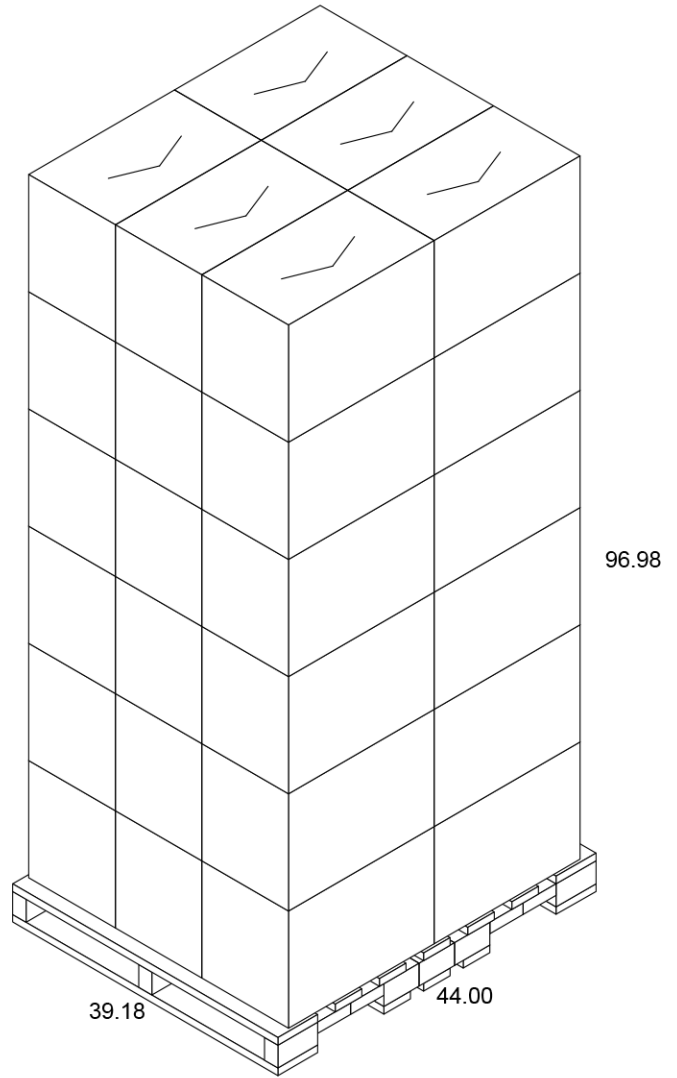
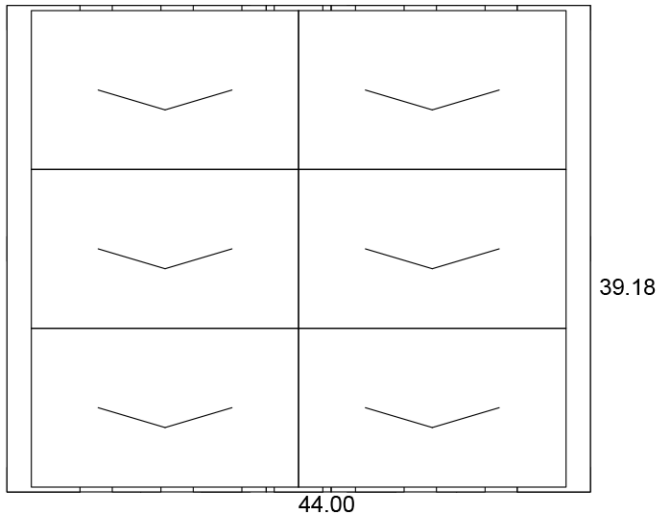
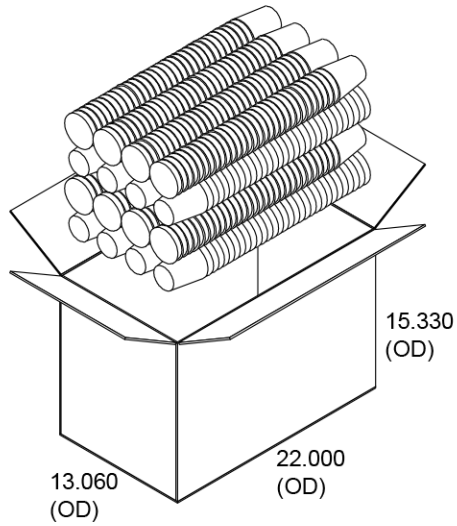

## Lid Options for X2D9 (Gloss), XHD9 (Matte)

8/9oz Double Wall Recycled Paper Cup



### Clear Single-Use Lid

- Clear, thermo-formed
- With & without straw slot
- Case: 1,000 - 7 lbs



### Cappuccino Lid

- White/Black, thermo-formed
- Vented lid
- Case: 1,000 - 8 lbs